

SanRex

Thyristor Type Power Adjusting Unit

CALPOTE

UF-3 series

INSTRUCTION MANUAL

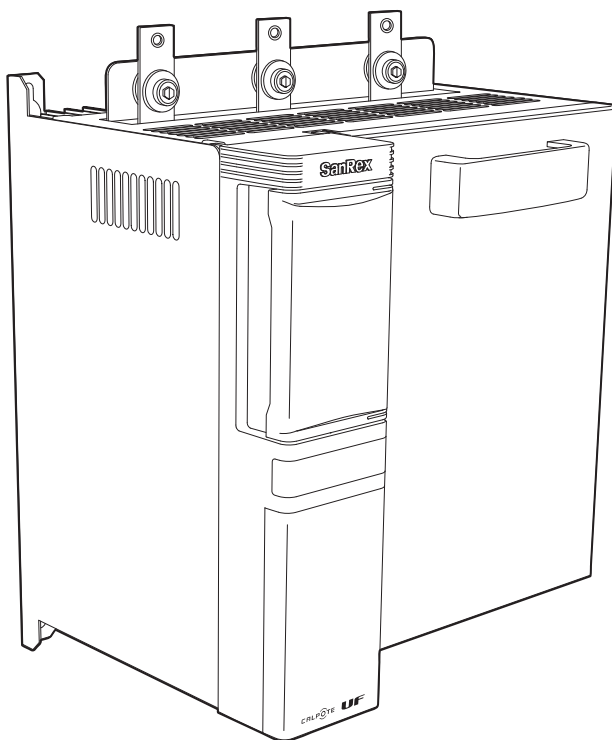

- In order to operate this product properly, operators and other persons concerned are all requested to read the "Safety Precautions" in this INSTRUCTION MANUAL thoroughly before using the product.
- Strictly forward this INSTRUCTION MANUAL to the end users.

TABLE OF CONTENTS

FORWARD	1
SAFETY PRECAUTIONS.....	2
■ Safety precautions to be observed by operators.....	2
■ Limitations for working environments	3
■ Precautions in installation	3
■ Precautions in wiring.....	4
■ Precautions in operation.....	4
■ Precautions in maintenance and inspection.....	5
PRECAUTIONS BEFORE USE	6
■ Confirmation of the product	6
CONNECTION DIAGRAM OF UNIT	7
EXTERNAL CONNECTION DIAGRAM OF UNIT.....	8
■ Connection diagram for each setting system	8
■ How to connect unit control cables	9
HOW TO SET UNIT	10
■ setting of dip switch S1	10
■ setting of dip switch S3.....	11
FUNCTION CHARACTERISTICS	12
DETECTION OF ABNORMALITY	13
■ Detection and indication of abnormality	13
■ Self-diagnostic function.....	15
■ External warning circuit	16
EXTERNAL DIMENSIONS OF UNIT	17
FUSE TO BE USED	18
OTHERS	19
■ Precautions in use.....	19
■ Maintenance and inspection.....	20
■ Troubleshooting.....	20
Option	21
■ Display panel (Model UF-DP)	21
■ Conversion board (Model UF-TB).....	21
■ Communication function.....	21
UNIT SPECIFICATIONS.....	22

FORWARD

Thank you very much for having purchased our “Thyristor Type Power Adjusting Unit CALPATE UF3 Series”. The Thyristor Type Power Adjusting Unit has been widely used in various fields for its operability, reliability, or other superiorities.

Our company consistently developed and manufactured the power adjusting unit starting from Thyristor elements, and obtained user’s enjoyment and satisfaction on our various products.

Now we introduce our “Thyristor Type Power Adjusting Unit CALPATE UF3 Series” that we have developed with confidence based on actual records accumulated through many years.

In this UF3 series, an insulation-type Thyristor module is introduced in the main circuit, contributing to the minimizing of the unit’s size and weight, while an one-chip microprocessor is loaded on the control circuit, enhancing functions and performance of the unit.

SAFETY PRECAUTIONS

Before installing, operating, maintaining, and inspecting this unit, be sure to read the present INSTRUCTION MANUAL and all other documents attached therein carefully in order for you to operate this unit properly. You and others concerned are requested to completely master all the know-how, safety instructions and precautions on the unit before use.

In this INSTRUCTION MANUAL, the following safety precautions are ranked as “DANGER” and “CAUTION” .



DANGER

A procedure which, if not properly followed, may cause extremely hazardous conditions, resulting in death or serious injury.



CAUTION

A procedure which, if not properly followed, may cause hazardous conditions, resulting in medium or slight injury and/or only damage on physical assets.

Further, note that articles, even if noted in the  , may cause a serious result depending on the situation. Strictly observe the articles since they describe important matters.

Sign indications for the “prohibited” and “required” actions are explained hereunder.



PROHIBITED

This sign indicates the “prohibition” that you should not do.
For example,  for “Use of Fire Strictly Prohibited” .



REQUIRED

This sign indicates the “compulsion” that you should do without fail.
For example,  for “Ground” .

■ Safety precautions to be observed by operators

 **DANGER**

To prevent serious injury to the operators and others, be sure to observe the following precautions.

- If live parts (input and output terminals) are exposed, be sure to house them in a box or to enclose them with a protective cover. Not doing so may cause electric shock, or fatal accidents resulting in death or serious injury.
- To secure safety, this unit must be installed, wired, maintained, inspected, and repaired by qualified persons or persons who are familiar with this unit.
- In the event of any failure of this equipment, off-flavor, and abnormal noise, cease its operation immediately. Not doing so may cause fire.

 **CAUTION**

To prevent electric shock, be sure to observe the following precautions.

- Never touch any parts that are electrically “live” or “hot” .
- Before wiring, maintaining, or inspecting this unit, turn off all the input power from a switch on the distribution panel, and check to see that power is OFF.
- When power is supplied to the unit, do not touch the cables connected to the power supply. Doing so may cause electric shock or burns.

■ Limitations for working environments

⚠ CAUTION

Absolutely do not operate nor store this unit in the following environments. Doing so may cause any failure in, damage to, or deterioration of the unit, resulting in fire.

- In hot, cold, or damp areas which are not in compliance with the requirements for ambient environments specified in relevant catalogs and this INSTRUCTION MANUAL
- In area where exposed to direct sunlight
- In area where subjected to vibration or shock
- In the vicinity of the equipment that produces sparks
- In area where exposed to dust, conductive dust, corrosive gases, salinity, or flammable gases, and
- Outdoors

■ Precautions in installation

⚠ CAUTION

- Attach the unit vertically and perpendicularly in such a manner that a marking of its model is properly legible.
(Horizontal attaching of the unit will increase the temperature of it excessively.)
- When use the unit in the environment that dust produces, please attach the unit in the installation. In addition, please make measures so that dust does not enter in the installation.
- Locate the unit at a well-ventilated and dust-free place to the extent possible.

- Secure spaces necessary for discharging heat on the top and bottom and both sides of the main body.

When stacking two or more units especially, give a sufficient space between units so that heat from the lower unit does not affect the upper unit.

If you intend to install a communication function into the unit, attach a communication unit on the left side of the unit body. Attach units in consideration of the size of communication unit sized to 24mm wide. Additionally, keep sufficient space so that its front door can be opened and closed for maintenance and inspection.

- The working ambient temperature of the unit is 50°C or below. Please do not use the unit at any higher temperature.
- The working ambient humidity of the unit is 90%Rh or below. Please do not use the unit at any higher humidity.
- When attach the unit, please secure safe work space.

In addition, please do work of installation and the disassembly of the unit in higher than two without doing work of installation and the disassembly of the unit alone when weight is more than 15kg.

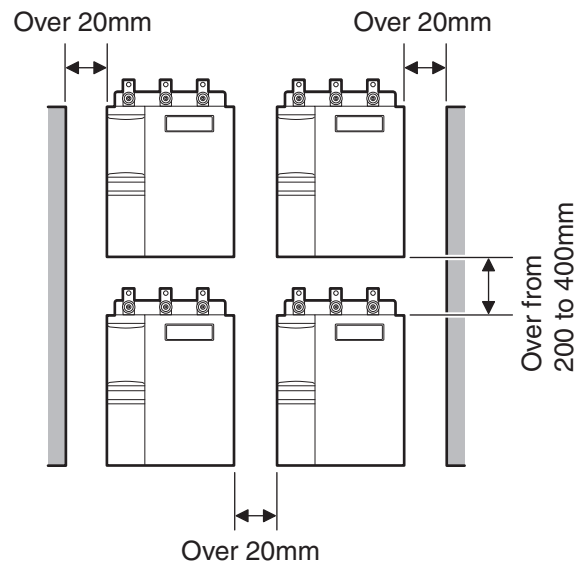

■ Precautions in wiring

CAUTION

- Ask a specialist contractor for wiring work.
Imperfect wiring work may cause electric shock or fire.

○ Precautions to be taken by a specialist contractor

DANGER

- Qualified specialists are required to turn off all the input power from a switch on the distribution panel and to make sure that power is off before connecting the input and output cables.
- The specialists must put a “Do not turn on this switch!” sign on the switch of the power distribution panel in order to prevent others than the specialists from touching the switch. Not doing so may cause electric shock or injury.
- Be sure to insulate the conductive parts which are connected to the power supply with insulating material (tube, tape, and others) . Exposure of such parts may cause electric shock or short-circuiting to the power supply, resulting in fire.

CAUTION

- Select the input and output cables of gauges suitable for this unit. Excessively small gauges of cables may cause overheating or fire.
- Use the cables of a dielectric strength suitable for the circuit voltage. The cables not having sufficient dielectric strength may cause electric shock.
- Be sure to use the crimp-type terminal for connections to the input and output terminals.
Improper connection may cause electric shock.

■ Precautions in operation

DANGER

- Do not remove a unit cover. Doing so may cause electric shock.
- Do not insert fingers or metal rods into the opening. Doing so may cause electric shock.
- In the event of any failure of this unit, off-flavor, and abnormal noise, stop its operation immediately.
Not doing so may cause fire.

CAUTION

- Do not insert fingers or rods into the opening. Doing so may cause caught-in accident by a cooling fan, resulting in injury.
- Do not touch the input and output terminal portions of the unit with a metal rod or fingers. Doing so may cause electric shock or injury.

■ Precautions in maintenance and inspection

PROHIBITED

- Persons other than approved persons (specialists) must not maintain, inspect, or repair this unit. Doing so may cause electric shock, injury, or fire.

CAUTION

- To repair this unit or to replace defective parts, please contact the distributor of your purchase or any service company.

○ Precautions to be taken by a specialist contractor

DANGER

- When performing maintenance, inspection, or repair, be sure to wear sufficiently safe clothing. Not doing so may cause electric shock or injury.
- When performing maintenance, inspection, or repair, turn off all the input power from a switch on the distribution panel, and check to see that power is OFF. Not doing so may cause electric shock or injury.
- The workers must put a “Do not turn on this switch!” sign on the switch on the power distribution panel in order to prevent others than the workers from touching the switch. Not doing so may cause electric shock or injury.

CAUTION

Before maintaining, inspecting, or repairing this unit, read this INSTRUCTION MANUAL thoroughly to perform proper work. Improper work may cause electric shock or fire.

- Before performing work, remove metal objects such as watches. Wearing metal objects during work may cause electric shock or injury.
- When performing work, place a sign, “Keep out! Authorized personnel only!”, in the working area to prevent other persons from entering the working area inadvertently. Not doing so may cause electric shock or injury.
- Use insulated tools. Not doing so may cause electric shock.
- Do not touch the high temperature parts such as transformers and heat discharging fin. Such parts may cause injury even after turning off power.
- Select replacement parts of same ratings and same type. Not doing so may cause fire.

PRECAUTIONS BEFORE USE

■ Confirmation of the product

Check the following items before installation.

- Check if correct products and optional items are provided as specified in the order.

[Main body]

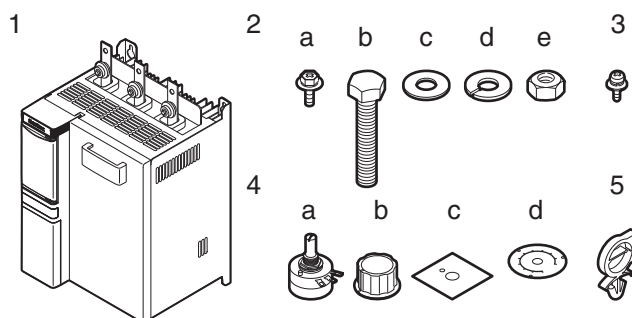

No.	Included items	Q'ty
1	UF3 unit body	1 unit
2	Screws, nuts, and others for the connection of output wires	
	a: Screw (25A-250A only)	6 pcs
	b: Bolt (350A and 450A only)	6 pcs
	c: Washer (350A and 450A only)	12 pcs
	d: Spring washer (350A and 450A only)	6 pcs
	e: Nut (350A and 450A only)	6 pcs
3	Screw for the connection of a grounding terminal	1 pcs
4	Attachment volume set	1 set
	a: Volume (1kΩ B characteristic)	1 pcs
	b: Knob	1 pcs
	c: Insulation sheet	1 pcs
	d: Nameplate (manual output adjustment, setting of the grade)	2 pcs
5	Easy lock	3 pcs

[Option]

Option name	Model
Display panel	UF-DP
Conversion board	UF-TB***
RS485 communication unit	UF-RS485
DeviceNet communication unit	UF-DN
CC-Link communication unit	UF-CL
PROFIBUS communication unit	UF-PB

* 3 models of conversion boards, 21A, 33, 33U, are available.

Refer to the "INSTRUCTION MANUAL for Conversion Board" for details.

- Check if necessary PT and CT are provided for the unit when equipped with an optional conversion board (UF-TB***).
- Check if the product has no damage due to accident during transportation or other causes.

CONNECTION DIAGRAM OF UNIT

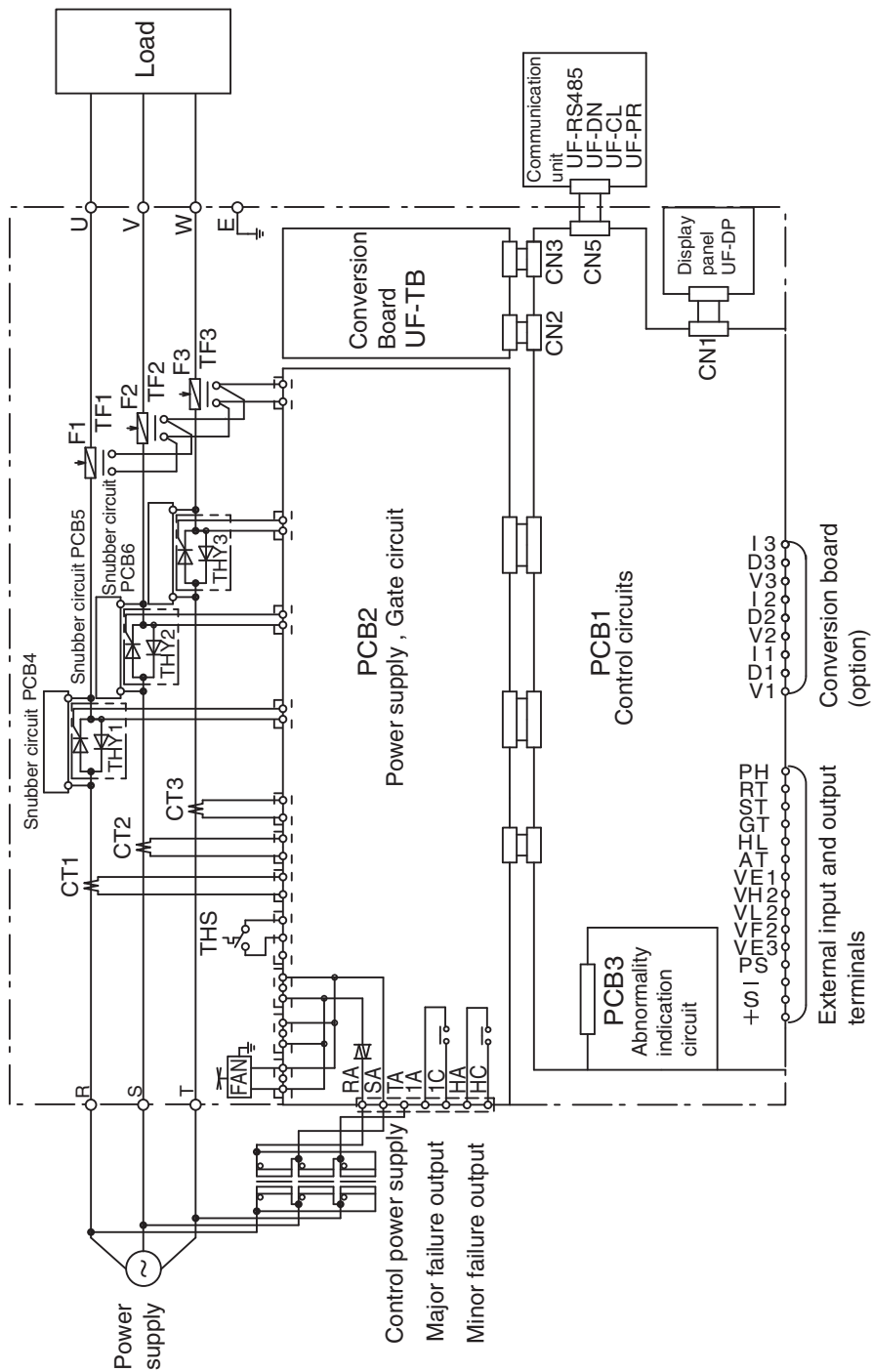

* For wiring of the external input terminals, refer to the Connection Diagram for Each Setting System.

* Use a transformer to obtain a 200/220V of the control power when other value of the power supply voltage is supplied for the main circuit. Align the polarities between the main and control circuits for wiring.

THY1-3	Thyristor
FAN	Cooling fan (forced air cooling only)
F1-3	Fuse
TF1-3	Fuse warning contact

CT1-3	Current transformer
PCB	Printed circuit board
CN	Connector
THS	Thermal switch

EXTERNAL CONNECTION DIAGRAM OF UNIT

■ Connection diagram for each setting system

Connection diagrams for each setting system are shown below.

- Short circuit between GT and PH terminals during operation. Open-circuiting between them during operation forcibly stops output.
- Short-circuiting between ST and PH terminals starts output, and open-circuiting between them stops output.
GT and ST terminals function differently in stop movement as listed below.

When GT and PH terminals are open-circuited, the GT terminal immediately stops output regardless of the soft start period.

When ST and PH terminals are open-circuited, the ST terminal gradually reduces output during the soft start period, and finally stops output.

When GT and ST terminals are short-circuited, both terminals gradually increase output to its set value during the soft start period.

- AT and PT terminals become automatic adjustment when short-circuited, and become manual adjustment when open-circuited.
- HL and PH terminals start output in case that the setting of an upper limit at short-circuit or of a lower limit at open-circuit is made.

• Manual adjustment

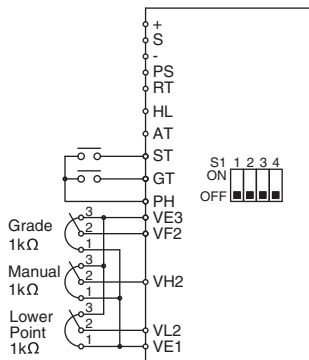

The setting of Grade, Manual, and Lower Point is selectively available.
 * In the case that Grade is not to be used, "VE3" and "VF2" are to be short-circuited.
 * In the case that Lower Point is not to be used, "VL2" and "VE1" are to be short-circuited.

• Two-position control

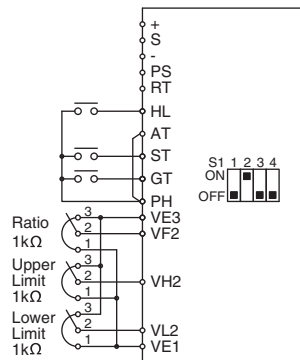

The setting of Ratio, Upper Limit, and Lower Limit is selectively available.
 * In the case that Ratio is not to be used, "VE3" and "VF2" are to be short-circuited.
 * In the case that Lower Limit is not to be used, "VL2" and "VE1" are to be short-circuited.

• Automatic adjustment (DC 4 to 20mA / 1 to 5V)

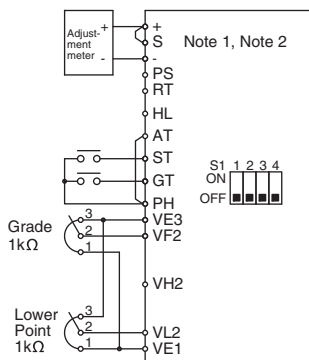

The setting of Grade and Lower Point is selectively available.
 Note 1 "+" and "S" are to be short-circuited in the case of a current signal.
 Note 2 "S" and "-" are to be short-circuited in the case of a voltage signal.
 * In the case that Grade is not to be used, "VE3" and "VF2" are to be short-circuited.
 * In the case that Lower Point is not to be used, "VL2" and "VE1" are to be short-circuited.

• Automatic adjustment (DC 0 to 5V)

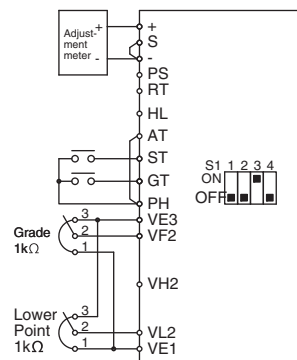

The setting of Grade and Lower Point is selectively available.
 * In the case that Grade is not to be used, "VE3" and "VF2" are to be short-circuited.
 * In the case that Lower Point is not to be used, "VL2" and "VE1" are to be short-circuited.

■ How to connect unit control cables

Use an easy lock to bind up the control cables (for control power supply, major failure output, minor failure output, external input and output terminals, and conversion board) of the unit.

1 Fix the easy locks on the unit.

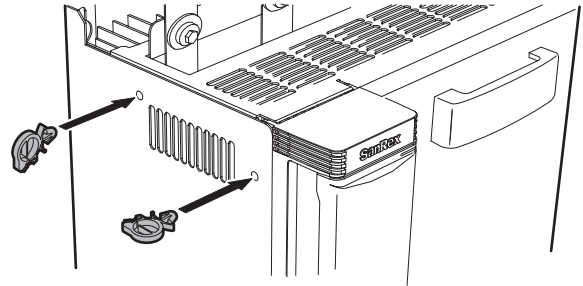

2 Bind the control cables with the easy locks. Separate the cables for the control power supply and other cables to bind.

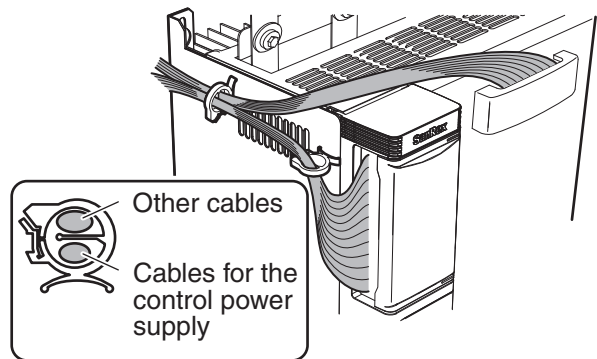

HOW TO SET UNIT

⚠ CAUTION

- Perform a setting of the unit with a good attention in that live parts are exposed when opening a cover of the unit. Before setting, turn off power.

The standard initial setting of this unit is as listed below. If the unit is used under other conditions, open a cover on the lower part of the unit to change the setting of dip switch S1 located on the printed circuit.

<input type="radio"/> Control system	Phase control
<input type="radio"/> Type of temperature control unit	DC4-20mA or DC1-5V
<input type="radio"/> Cycle control	Intermittent type

■ Setting of dip switch S1

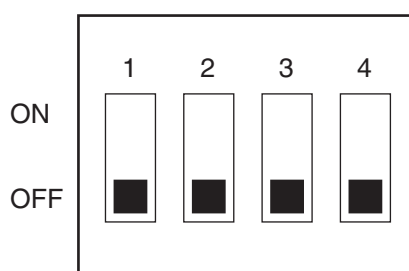

Item	Description	1	2	3	4
Control system	Phase control	OFF			
	Cycle control	ON			
Type of temperature control unit	DC1-5V/4-20mA		OFF	OFF	
	DC0-5V		OFF	ON	
	Two-position control		ON	OFF	
	Not defined		ON	ON	
Cycle control	Intermittent type				OFF
	Continuous type				ON

○ Control system (S1-1)

[Function] This makes a selection of phase control or cycle control. The phase control is to control the phase of half-cycle by means of its effective value.

The cycle control is to control the number of turning ON in one cycle during a certain constant period by means of its effective value. Changeover between phase and cycle controls is not possible during output operation. Changeover between phase and cycle controls is possible only while the power is turned off.

Use the S1-4 switches to change the setting of intermittent type/continuous type for cycle control. However, changeover of the control system is not made during output operation.

A system is provided to prevent the changeover of control system during its operation.

• Phase control waveform (In the case of 3 arm unit)

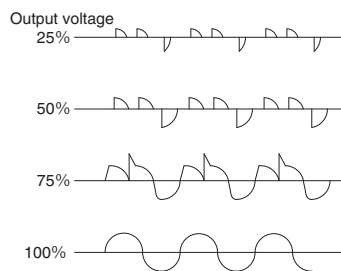

• Cycle control waveform (In the case of 3 arm unit)

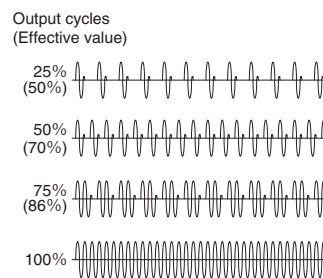

○ Type of temperature control unit (S1-2, 3)

[Function] This changes the signal levels sent from the temperature control unit, and selects the two-position control. Changeover of the operating conditions of temperature control unit is possible only while the power is at a standstill, but such changeover is not possible during output operation.

However, changeover of the type of the temperature control unit is not possible during output operation. A system is provided to prevent the changeover of the type of temperature control unit during operation.

○ Cycle control (S1-4)

[Function] This makes a selection of intermittent type or continuous type for cycle control.

Use the S1-1 switch to change the setting of phase control or cycle control.

However, changeover of the cycle control is not possible during output operation. A system is provided to prevent the changeover of cycle control during output operation.

• Intermittent type waveform (In the case of 3 arm unit)

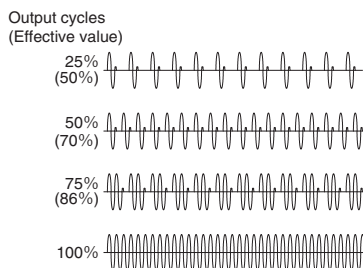

• Continuous type waveform (In the case of 3 arm unit)

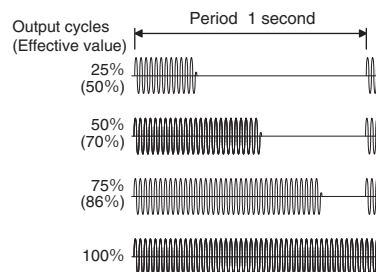

■ Setting of dip switch S3

S3 is a switch to change the setting of the unit address when an optional RS485 communication unit is installed. Therefore, leave the setting of the switch as initially set.

FUNCTION CHARACTERISTICS

The standard unit has the linear characteristic between control signals and output level. It can be changed to have the following characteristics.

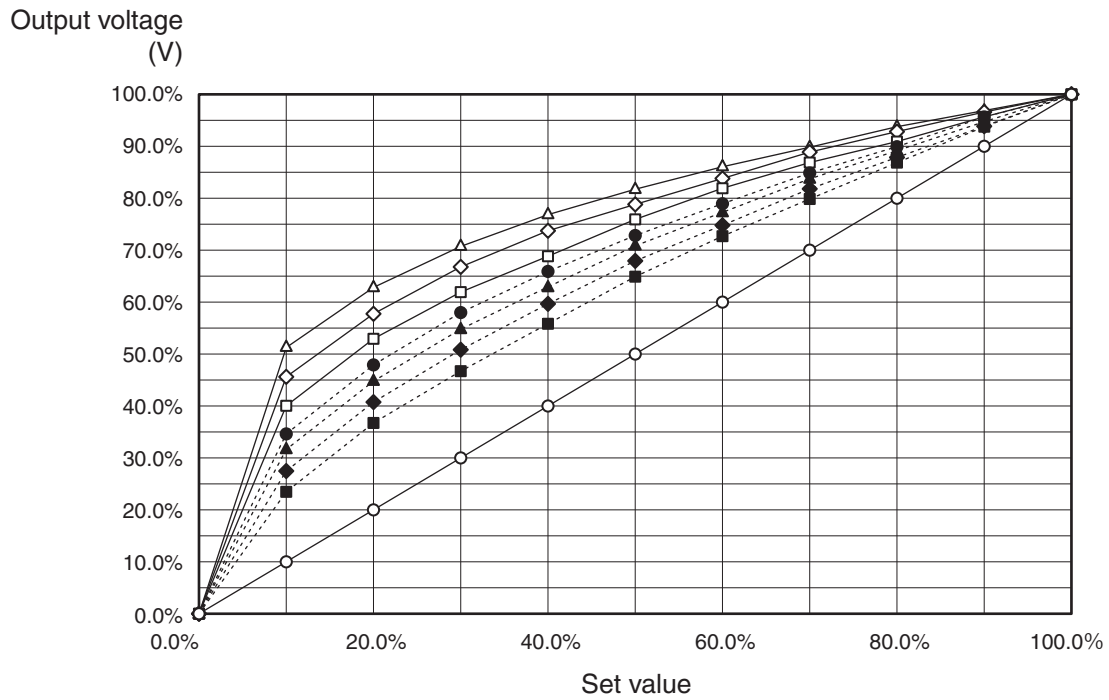

	Function characteristics No.	Input and output characteristics
—○—○—	Characteristic 0	Linear characteristic
---■---■---	Characteristic 1	1.6th root characteristic
---◆---◆---	Characteristic 2	1.8th root characteristic
—□—□—	Characteristic 3	2.0th root characteristic
---▲---▲---	Characteristic 4	2.2th root characteristic
---●---●---	Characteristic 5	2.5th root characteristic
—◇—◇—	Characteristic 6	3.0th root characteristic
—△—△—	Characteristic 7	3.5th root characteristic

DETECTION OF ABNORMALITY

■ Detection and indication of abnormality

⚠ CAUTION

- In the event of any abnormality, check the Unit Abnormality lamp, stop operation of the unit, and then turn off power.

When an abnormality detection circuit functions, an abnormality indication lamps lights up or flickers on the right-hand side of the terminal block inside the front panel of the unit.

Abnormality indications, abnormality descriptions, operating status, and procedures to restart operation are as listed below.

	Abnormality indication	Abnormality description	Operating status after detection of abnormality	Procedures to restart operation
Light-emitting diode is lit.	OCR	Detection of overcurrent	Operation stops.	Turn off power.
	TMP	Temperature rise abnormality	Operation stops.	Turn off power. * 1
	F	Fuse disconnection	Operation stops.	Turn off power.
	HET	Heater disconnection (optional)	Operation continues.	* 2
Light-emitting diode flickers.	THY	Thyristor short	Operation stops.	Turn off power.
		Thyristor open	Operation stops.	Turn off power.
	LOD	Load short	Operation stops.	Turn off power.
		Load open	Operation continues.	
	FRQ	Abnormal frequency	Operation continues.	
	L. Vo	Power supply undervoltage	Operation stops.	Operation is automatically recovered.

* 1 This abnormality is available only for an 100A unit or larger.

* 2 This abnormality is available only for an unit equipped with a conversion board for detection of heater disconnection (optional).

○ OCR

This detects overcurrent when the current exceeding 150 percent of the unit's rated current has flowed over several cycles. On detection of overcurrent, an "OCR" indication lights up and operation stops. To resume operation, turn off the control power supply.

○ TMP

This detects temperature rise abnormality when the temperature of a cooling fin has been increased abnormally. On detection of temperature rise abnormality, a "TMP" indication lights up and operation stops. To resume operation, turn off the control power supply.

○ **F**

This detects fuse disconnection when a fuse built in the unit is disconnected. On detection of fuse disconnection, an “F” indication lights up and operation stops. To resume operation, turn off the control power supply.

○ **HET**

The optional function is provided to detect heater disconnection. On detection of heater disconnection, an “HET” indication lights up and operation continues.

○ **THY**

The self-diagnostic function is provided to detect Thyristor open or short. On detection of Thyristor open or short, a “THY” indication flickers and operation stops. To resume operation, turn off the control power supply.

○ **LOD**

The self-diagnostic function is provided to detect load open or short. On detection of load open or short, an “LOD” indication flickers. Operation continues in the event of load open. Operation stops in the event of load short. To resume operation, turn off the control power supply.

○ **FRQ**

This detects abnormal frequency in the event of any abnormality with frequency of control power supply. On detection of abnormal frequency, an “FRQ” indication flickers and operation continues.

○ **L. Vo**

This detects power supply undervoltage when the voltage of control power supply falls below its appropriate value. On detection of power supply undervoltage, an “L. Vo” indication flickers. Operation is at a standstill only while such abnormality is detected. When the detection of abnormality is released, operation is automatically resumed.

■ Self-diagnostic function

This function is provided somewhat differently depending on the combination with a conversion board (optional).

	Without conversion board		With conversion board		Operating status after detection of abnormality
	In running	In stopping	In running	In stopping	
Thyristor open	△	N/A	Available	N/A	Operation stops.
Thyristor short	N/A	Available	N/A	Available	Operation stops.
Load short	Available	N/A	Available	N/A	Operation stops.
Load open	Available	N/A	Available	N/A	Operation continues.

* Only when conversion boards 33 (U) mounted.

* The item marked with △ is judged to be load short even in the case of Thyristor open.

Starting the unit without turning on the power of main circuit for test operation may cause its self-diagnostic function to stop operation. In such a case, release the self-diagnostic function once to restart operation.

To forcibly release the self-diagnostic function, use a thin bar-shaped item to press the SELF CHECK switch located on the lower-right part after opening a terminal cover on the front of the unit. When the switch for approximately one second is pressed, the abnormality indication lamps of “THY” and “LOD” on the upper part simultaneously flicker for about 1 minute. If the control power supply is turned off and then on during compulsory release of self-diagnostic function, the settings are stored during such compulsory release. When the control power supply is turned on, the abnormality indication lamps of “THY” and “LOD” flicker for about 1 minute simultaneously, indicating that the self diagnostic function is in compulsory release.

To recover the self-diagnostic function, press the SELF CHECK switch again. Doing so causes such abnormality indication lamps to go out in the case they are flickering simultaneously.

■ External warning circuit

The abnormality detection circuit, when activates, causes an external warning relay in the unit to activate. Major and minor failure relays are provided as the external warning relay.

○ Major failure relay

The abnormalities described below, when detected, forcibly stops operation and at the same time causes a major failure relay in the unit to activate.

- Detection of overcurrent
- Temperature rise abnormality
- Fuse disconnection
- Thyristor open/short and load short to be detected by self-diagnosis function

Use the output of the major failure relay contact to monitor any abnormality.

Normal	Between 1A and 1C	Opened
Abnormality	Between 1A and 1C	Closed
Specifications for relay contact	AC 250V	0.1A-1A
	DC 30V	0.1A-1A

The output of the major failure relay contact informs multiple abnormalities detected. So, check the indication of abnormality detection to know what abnormality was detected as a cause of activating the relay.

○ Minor failure relay

The abnormalities listed below, when detected, causes a minor failure relay in the unit to activate.

- Power supply undervoltage
- Abnormal frequency
- Load open to be detected by self-diagnostic function
- Detection of heater disconnection (optional)

There may be the cases that power supply undervoltage and abnormal frequency are detected when the control power supply is turned on/off. Therefore, the relay does not activate for about 3 seconds after detection of such abnormalities even when they are actually detected.

Use the output of the minor failure relay contact to monitor any abnormality.

Normal	Between HA and HC	Opened
Abnormality	Between HA and HC	Closed
Specifications for relay contact	AC250V	0.1A-1A
	DC30V	0.1A-1A

The output of the minor failure relay contact informs multiple abnormalities detected. So, check the indication of abnormality detection to know what abnormality was detected as a cause of activating the relay.

EXTERNAL DIMENSIONS OF UNIT

Model	Rated current	Cooling system	External dimensions (mm)						Weight (kg)	Calorific value (W)	Terminal screw
			A	B	C	D	E	F			
UF3-0025□ F	25A	Self-cooling	200	180	240	256	270	190	6	87	M6
UF3-0035□ F	35A	Self-cooling	200	180	240	256	270	190	6	114	M6
UF3-0050□ F	50A	Self-cooling	200	180	240	256	270	190	6	174	M6
UF3-0075□ F	75A	Self-cooling	200	180	240	256	270	230	7	252	M6
UF3-0100□ F	100A	Air-cooling	230	210	240	256	270	230	10	312	M6
UF3-0150□ F	150A	Air-cooling	230	210	350	366	380	260	13	522	M8
UF3-0250□ F	250A	Air-cooling	360	340	350	366	380	260	19	936	M10
UF3-0350□ F	350A	Air-cooling	360	340	425	437	455	260	28	1140	M12
UF3-0450□ F	450A	Air-cooling	360	340	425	437	455	260	28	1560	M12

* □ = None: 3-arm

* □ = K: 6-arm

• 25A-50A

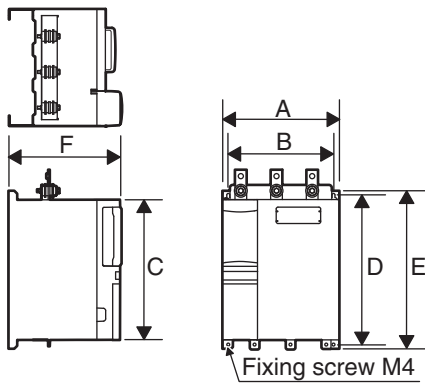

• 75A-100A

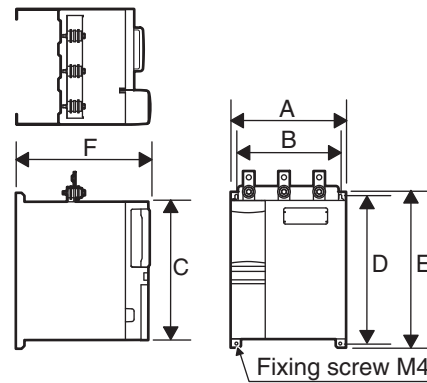

• 150A-250A

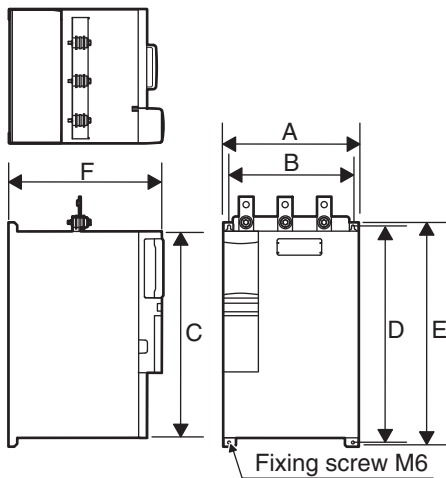

• 350A/450A

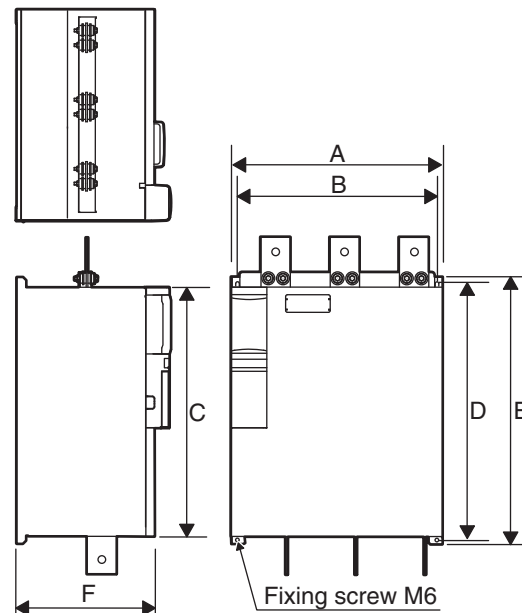

FUSE TO BE USED

Unit current	Fuse 200V/400V
25A	660GH 50S-F
35A	660GH 63S-F
50A	660GH 100S-F
75A	660GH 125S-F
100A	660GH 160S-F
150A	660GH 250S-F
250A	660GH 350S-F
350A	660GH 500S-F
450A	660GH 710S-F

OTHERS

■ Precautions in use

- Use cables with sufficient capacity to the rated current of the unit, for wiring of the main circuit.
- For wiring of the main circuit, connect a R, S, T terminal to the power supply side, and an U, V, W terminal to the load side.
- Securely align the phase of power supply for main circuit with the same for control circuit.
- Do not bind cables for control circuit with those for main circuit.
- In the case of low capacity load (approx. 10% of rated capacity or lower) , the “LOD” indicator lamp may light up by self-diagnostic function, but this does not give any problem on operation.
- When storing the unit in the cabinet, provide ventilation in consideration of the internal calorific value by the unit.
(The internal calorific value is specified in the “External Dimensions of Unit” section.)
- In the case of low capacity load, a leakage current may be applied onto the load side, causing any malfunction even if the signal is off.
So connect a bleeder resistor in parallel with the load. (The minimum load current is 1A or more.)
- Be sure to attach the unit vertically and perpendicularly with an attachment space secured as instructed in the “Precautions in Installation” . Attaching the unit in the horizontal direction or reducing the attachment space will adversely affect a cooling effect and abnormally increase the temperature of the unit.
- Attach the unit so that its front door can be opened and closed for maintenance or inspection.
- Do not apply 5V or more, or 20mA or more from the temperature control unit.
- In the case of transformer load, recommend the use of 6-arm units.
- In the case of inductive load (including transformer load), a voltage exceeding the rating may be applied onto the load side of the unit caused by abnormal voltage due to oscillation under low load, or by surge voltage due to gate block (including ON/OFF from the GT terminal) or service interruption under transformer load, and other reasons. Therefore, install a CR absorber on the load side of the unit.

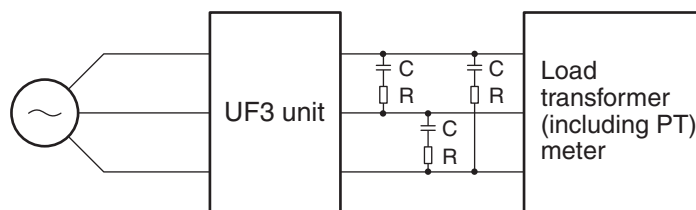

Current (A)	200V system unit		400V system unit	
	Capacitor (μF)	Resistor (Ω)	Capacitor (μF)	Resistor (Ω)
25-100	0.5 (AC480V)	50 (120W) or 100 (60W) 2 parallel	1.0 (AC800V)	50 (120W) or 100 (60W) 2 parallel
150-350	1.0 (AC480V)	20 (120W) or 40 (60W) 2 parallel	1.0 (AC800V)	50 (120W) or 40 (60W) 2 parallel
450	2.0 (AC480V)	20 (120W) or 40 (60W) 2 parallel	2.0 (AC800V)	20 (120W) or 40 (60W) 2 parallel

■ Maintenance and inspection

- It is noted that dust, moisture, overheating, vibration, and others may degrade performance or cause any failure of the unit.
- Securely turn off the power for main and control circuits when conducting maintenance and inspection. Keep in mind that any voltage is applied to the circuit even after the start/stop switch is set to stop.
- When a warning circuit functions, an abnormality indication lamps lights or flickers on the front side window of the unit. So turn off the power after checking the content of warning.
- When the “OCR” or “F” is lit, any abnormal current is applied onto the unit. Eliminate possible causes to restart operation in such case.
- When the “TMP” is lit, a cooling effect is worsened due to any failure of a fan and other causes. Replace such fan with a new one to enhance the cooling effect, and then re-operate the unit.
- When the “THY” flickers, a Thyristor is faulty, or the abnormality detection lines are disconnected or short-circuited. Replace such Thyristor with a new one or check the lines, and then re-operate the unit.

■ Troubleshooting

If occurrence of a trouble is suspected, read this INSTRUCTION MANUAL carefully to inspect the following items. If the trouble is not solved yet, be sure to turn off the power supply of the unit, and contact our distributors nearest you or our business offices.

Situation	Possible causes	Remedy
Output does not come out.	Is not the control power 160V or less?	Adjust the power supply voltage to 200/220V.
	Are not lines between ST and PH opened?	Short-circuit between ST and PH.
	Are not lines between GT and PH opened?	Short-circuit between GT and PH.
	When the setting of grade is not used, are not lines between VF2 and VE3 opened?	Short-circuit between VF2 and VE3.
	Is the setting of grade 0?	Increase the grade.
	Is a phase of the power supply for main circuit aligned with the same for control circuit? (There may be the case that the LOD flickers.)	Align both phases.
	Is wiring improper?	Check wiring.
	Is any of the abnormality indication lamps lit or flickering?	Eliminate possible causes, and then turn on/off the control power.
Is switch S1 set improperly?	Check its setting procedure again.	
Output is abnormal.	Are polarities of PT and CT aligned in the case of constant power control?	Align such polarities.
	Is switch S1 set improperly?	Check its setting procedure again.
	Is conversion board set improperly?	Check its setting procedure again.

OPTION

■ Display panel (Model UF-DP)

○ Functions

Using a display panel provides the following functions. Read the “INSTRUCTION MANUAL for Display Panel” for details.

- Can display output current, voltage, and power for checking.
- The percentage of the setting of the control signal sent from the temperature control unit, manual (upper limits), lower point (lower limits), and grade signal can be displayed for checking.
- Arbitrary setting of the control signal, manual (upper limits), lower point (lower limits), and grade signal without externally attaching a volume is possible from the display panel.
- Arbitrary setting of the soft-start time, current limit, and detection of heater disconnection is possible from the display panel.
- Controlling of Start/Stop is possible from the display panel.
- The functional feature allows the selection of seven types of input/output characteristics in addition to linear type. One of seven types allows arbitrary setting of input/output characteristics. Additionally, the value once set is stored even after power is turned off.

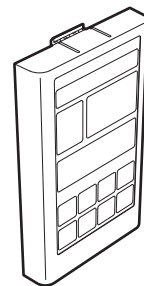

■ Conversion board (Model UF-TB)

○ Function

Using a conversion board provides the following functions. Read the “INSTRUCTION MANUAL for Conversion Board” for details.

- Can control output by constant voltage, constant current, and constant power controls.
- Heater disconnection can be detected for checking.
- Using the conversion board in combination with the display panel enables to display output current, voltage, and power.
- Can contribute to enhancing the self-diagnostic function. However, each function varies depending on the type of the conversion board.

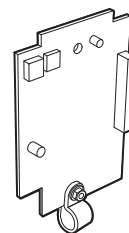

■ Communication function

This unit is applicable to the Open Network communication system such as DeviceNet, etc. Any inquiry about its communication function should be addressed to our sales department.

Communication unit	Applicable network
UF-RS485	RS485 communication unit
UF-DN	DeviceNet communication unit
UF-CL	CC-Link communication unit
UF-PB	PROFIBUS communication unit

UNIT SPECIFICATIONS

Description		Specifications
Models		3-arm : UF3-0***F 6-arm : UF3-0***KF
Main circuit	Phase	Three phase
	Rated input voltage	100/110/120V , 200/220/254V , 380/400/440/460/480V
	Fluctuation range of power supply	±10%
	Rated frequency	50/60Hz (automatic judgment system of frequency)
	Rated current (at ambient temperature of 50°C)	25A, 35A, 50A, 75A, 100A, 150A, 250A, 350A, 450A (600A, 800A, 1200A Semi-standard)
Control circuit	Control power supply	AC200/220V Three-phase 50VA (150VA for 100A unit or larger)
	Performance assurance voltage	AC180V~AC242V
	Operation assurance voltage	AC160V~AC242V
	Power supply for fan	Common use with the control power supply (100A unit or larger)
Control system		Phase control Cycle control (Intermittent type/Continuous type) Feedback control is not available for continuous type.
Adjusting range of output voltage		Phase control 0%~98% (Effective value) Cycle control 0%~98% (Effective value) (at number of cycles of 100%)
Setting range of grade		0%~100% (with reference to output)
Setting range of lower point		0%~100% (with reference to output)
Input and output properties		Linear properties ±3% F.S. (at 10~90% output) But, in the case of cycle control of continuous type is linear properties ±5% F.S.
Ambient temperature		-10°C~50°C (at humidity of 90%RH or below)
Storage temperature		-20°C~70°C
Applicable load		Phase control : resistive load, inductive load, transformer primary side control Cycle control : resistive load
Control signal		Current signal : DC4mA~DC20mA (with internal resistor of 250Ω) Voltage signal : DC1V~DC5V, DC0V~DC5V (with internal resistor of 10kΩ)
Start/Stop system		Soft start/down system 0.5sec (standard) (Setting between 0.0 sec and 300 seconds is possible from the display panel.)
Cooling system		Self-cooling for 75A unit or smaller Air-cooling for 100A unit or larger
Warning output function	Major failure relay	Operates in the event of overcurrent, abnormal temperature, fuse disconnection, Thyristor open/short, and load short. Contact output : 1a contact (AC250V 1A) Warning indication : The light-emitting diode of OCR, TMP, or F lights up, and the same of THY or LOD flickers.
	Minor failure relay	Operates in the event of power supply undervoltage, abnormal frequency, load open, and heater disconnection. Contact output : 1a contact (AC250V 1A) Warning indication : The light-emitting diode of HET lights up, and the same of L.Vo, FRQ, or LOD flickers.
Function to limit current		Setting between 50% and 110% of rated current is possible.
Detection of instantaneous power failure		Detects power failure (half cycle or more) and turns off output. Restarts output in the soft-start mode after power is recovered.
Dielectric strength		AC2500V for 1 minute
Insulation resistance		20MΩ or more (by DC500V)

-MEMO-

 **SANSHA ELECTRIC MFG. CO.,LTD.**

Head Office

3-1-56 Nishiawaji, Higashiyodogawa-ku, Osaka
533-0031, Japan
Tel: 06-6325-0500 Fax: 06-6321-0355
<http://www.sansha.co.jp/>

SANREX CORPORATION (U.S.A)

50Seaview Boulevard Port Washington, NY 11050-4618,
U.S.A
Tel: +1-516-625-1313 Fax: +1-516-625-8845

SANREX EUROPE GmbH (Germany)

Knorrstrasse 142, Munich D-80937, Germany.
Tel: +49-89-311-2034 Fax: +49-89-316-1636

SANREX LIMITED (Hong Kong)

Room 307, Kowloon Plaza, 485 Castle Peak Rd.,
Kowloon, HongKong
Tel: +852-2744-1310, +852-2785-6313
Fax: +852-2785-6009

SANREX ASIA PACIFIC PTE.LTD. (Singapore)

25, Tagore Lane, #04-02B Singapore Godown, 787602
Singapore
Tel: +65-6457-8867, +65-6459-6426 Fax: +65-6459-6425

FOSHAN CITY SHUNDE SANREX LIMITED (China)

Dazhou Shiliang Road Lunjiao Town, Shunde District,
Foshan City, Guandong Province 528308 P.R.China
Tel: +86-757-2733-3688 Fax: +86-757-2783-3547

**SANSHA ELECTRIC MFG. (SHANGHAI) CO.,LTD
(China)**

Room310,555 Building,555West Nanjing Road,
Shanghai 200041,P.R.China
Tel: +86-21-5868-1058 Fax: +86-21-5868-1056