

The SANPAW 300PW Plasma welding system has many advantages over traditional automated TIG welding including: increased productivity, consistent arc starting, improved process control and reduced electrical emission interference.

This unique plasma welding system is self contained in a small package with a 300 amp power

supply, control console and Sequencer. Our design reduces floor space and simplifies installation, making the initial price competitive with automated TIG systems while its increased productivity and repeatable performance allow it to pay for itself in a shorter period of time.

Features and Benefits of the SANPAW 300PW

- 5-300 Amp current range - providing quality performance on a wide variety of applications.
- Smooth DC arc - repetitive, high quality welds.
- Pilot Arc - repeatable arc starting reducing defects and rework.
- Multiple Voltage Input - 200-230/460 VAC, 3 phase, 50 or 60 hz.
- Current Limiter - limits power source output to torch capability to avoid torch damage.
- Preview Set Current - eliminates costly test set-ups/displays actual current/voltage.
- Included Weld Sequencer (Current Sloper/Pulser).
- Save 30 Programs.
- Protection devices:
 - Coolant conductivity warning circuit.
 - Coolant flow protection/interlock.
 - Coolant temperature protection/interlock.
 - Console temperature overload detection/interlock.
- Simple to setup: A self-contained unit, which requires attaching input power, Coolant recirculator and gases, then mounting the torch.
- Simple interface - automated or manual control.
- Can utilize a number of competitive torches.
- 3 Year Warranty.



SANPAW 300PW

DC Plasma Welding

The SANPAW 300PW system Package is shipped with the SANPAW 300PW unit, Coolant Recirculator, Gas & Water Hoses and a appropriate torch with a torch spare parts kit. Systems do not include Input Cable, Work Lead, Regulators and Remotes.

Torch (Rating)	System Description	w/12.5 ft. Torch and Leads	w/25 ft. Torch and Leads
P-15 (150 amps)	PWH-P15, 70 degree	PAW300P1570H125	PAW300P1570H25
	PWH-P15, 90 degree	PAW300P1590H125	PAW300P1590H25
	PWH-P15, 180 degree	PAW300P15180H125	PAW300P15180H25
	PWM-P15, 180 degree	PAW300P15180M125	PAW300P15180M25
P-22 (220 amps)	PWH-P22, 70 degree	PAW300P2270H125	PAW300P2270H25
	PWH-P22, 90 degree	PAW300P2290H125	PAW300P2290H25
	PWH-P22, 180 degree	PAW300P22180H125	PAW300P22180H25
	PWH-P22A, 180 degree	PAW300P22180HA125	PAW300P22180HA25
	PWM-P22, 180 degree	PAW300P22180M125	PAW300P22180M25
	PWM-P22A, 180 degree	PAW300P22180MA125	PAW300P22180MA25
P-30 (300 amps)	PWH-P30, 180 degree	PAW300P30180H125	PAW300P30180H25
	PWM-P30, 180 degree	PAW300P30180M125	PAW300P30180M25

- PWH designates a torch with a molded handle.
- PWM designates a torch with rack and pinion.
- Torch amperage rating based on minimum electrode set back.

SANPAW 300PW (Unit Only) ID-3000PW-U1E

- *Dynaflux® R2000 (115vac) Recirculator TK-1016

*Note: When using equivalent cooling system refer to the Torch manufacturers cooling requirements.

- **Argon Regulator MS-1005
- **Hydrogen Regulator MS-1006

**Note: 2 required, one for Plasma Gas and one for Shield Gas.

12.5 ft. Gas Hose (2 Required) MS-1000

12.5 ft. Water Hose (2 required) TK-1000

Remote Controls

- 25 ft. Foot Control FC-1001
 - 25 ft. Hand Pendant HP-1425
 - 1 ft., 14-pin Amp to 14-Pin Amphenol ADC001
- Coolant (1Gal) TK-1017



Torch Parts

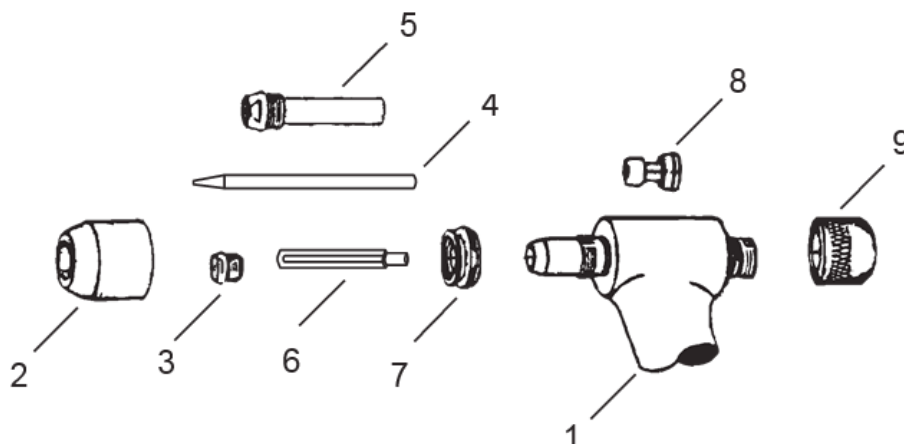

Common Torch Consumables.

ITEM NO.	PART DESCRIPTION	P-15 TORCH	P-22 TORCH	P-30 TORCH
2	Shield Cup	P15-3001	P22-3001	P30-3001
3	Tip	P15-3005 (.031) 35A-Ig P15-3006 (.046) 50A-Ig P15-3007 (.062) 75A-Ig P15-3008 (.081) 100A-Ig P15-3009 (.093) 130A-Ig	P22-3003 (.062) 100A-Ig P22-3004 (.093) 125A-Ig P22-3005 (.125) 150A-Ig*	P30-3005 (.093) 200A-Ig P30-3006 (.113) 250A-Ig P30-3007 (.125) 300A-Ig*
4	Electrode	P15-3015 (.093) std. P15-3016 (.093) ext.	P22-3009 (.187) std. P22-3010 (.187) ext.	P30-3008 std.
5	Liner	N/A	P22-3011	P30-3009
6	Gas Distributor (insulating sleeve)	P15-3017	P22-3012	P30-3010
7	Gas Diffuser	P15-3019	P22-3015	P30-3012
8	Collet Assembly	P15-3021	P22-3018	P30-3014
9	Back Cap	P15-3022 (std-electrode) P15-3023 (ext-electrode)	P22-3019 (std-electrode) P22-3020 (ext-electrode)	P30-3015 (std-electrode) N/A (ext-electrode)
N/S	Collar	N/A	P22-3016	N/A
N/S	O-ring (liner)	N/A	N/A	P30-3017
N/S	O-ring (internal)	N/A	N/A	P30-3018
N/S	O-ring (back-cap)	P15-3020	P22-3017	P30-3013
N/S	Gasket (shield cup)	P15-3018	P22-3013	P30-3011
N/S	Lubricant	PAW-LUBE	PAW-LUBE	PAW-LUBE

NOTE: The use of extended electrode requires an extended back cap.

Tip ratings @ minimum electrode setback.

*Tip maximum current rating not to exceed the maximum output of SANPAW 300PW.

Torch Specifications

Torch Model	Type	Part No.	Torch Lead Length	Current Rating	Coolant Requirements	Torch Dimensions					
						A	B	C	D	E	
P15 Torch	PWH-P15 70°	P15-1000 (H)	12.5 ft.	150 Amps (DCSP)	6,000 BTU/hr (1513 K/Cal/hr) 1/3 gpm coolant flow @ 50 PSI (1.25 lpm @ 3.7 kg/cm ²)	8-3/4"	2-5/8"	7/8"	1-1/16"		
		P15-1001 (H)	25 ft.			(222 mm)	(67 mm)	(22 mm)	(27 mm)		
	PWH-P15 90°	P15-1002 (H)	12.5 ft.			8-1/2"	2-5/8"	7/8"	1-1/16"		
		P15-1003 (H)	25 ft.			(216 mm)	(67 mm)	(22 mm)	(27 mm)		
	PWM-P15 180° Offset	P15-1004 (H) P15-1005 (M)	12.5 ft.			19-1/4"	1"	Min. 9-1/4"	Max. 16-3/4"	1-3/8"	
		P15-1006 (H) P15-1007 (M)	25 ft.			(489 mm)	(25 mm)	(235 mm)	(425 mm)	(35 mm)	
P22 Torch	PWH-P22 70°	P22-1000 (H)	12.5 ft.	200 Amps (DCSP)	8,000 BTU/hr (2017 K/Cal/hr) 1/2 gpm coolant flow @ 50 PSI (1.9 lpm @ 3.7 kg/cm ²)	12-1/2"	3-3/16"	1-1/4"	1-3/8"		
		P22-1001 (H)	25 ft.			(318 mm)	(81 mm)	(32 mm)	(35 mm)		
	PWH-P22 90°	P22-1002 (H)	12.5 ft.			12-1/4"	3-3/16"	1-1/4"	1-3/8"		
		P22-1003 (H)	25 ft.			(311 mm)	(81 mm)	(32 mm)	(35 mm)		
	PWM-P22 180° Offset	P22-1004 (M)	12.5 ft.			18"	1-3/4"	Min. 8-1/4"	Max. 16"	1-3/8"	1-1/4"
		P22-1005 (M)	25 ft.			(457 mm)	(44 mm)	(209 mm)	(406 mm)	(35 mm)	(32 mm)
	PWM-P22A 180° Inline	P22-1006 (H) P22-1008 (M)	12.5 ft.			21"	1-3/4"	Min. 11-1/4"	Max. 19"	1-3/8"	1-1/4"
		P22-1007 (H) P22-1009 (M)	25 ft.			(.53 m)m	(44 mm)	(286 mm)	(483 mm)	(35 mm)	(32 mm)
P30 Torch	PWM-P30 180° Offset	P30-1000(M)	12.5 ft.	300 Amps (DCSP)	12,000 BTU/Hr (3026 K/Cal/hr) .75 gpm coolant flow @ 100 psi 2.84 lpm @ 7 kg/cm ²	22.19"	2.5"	Min. 12.44"	Max 20.19"	1.38"	1.63"
		P30-1001(M)	25 ft.			(56.4cm)	(6.35cm)	(31.6CM)	(51.3cm)	(3.5cm)	(4.14cm)

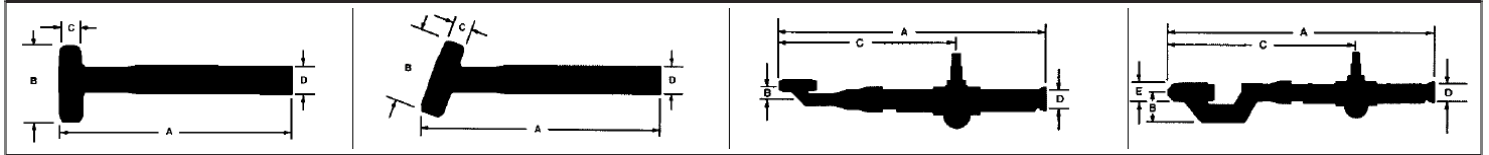

Note: For complete torch details see operation manual.

(H) designates torch with molded handle.

(M) designates torch with rack and pinion assembly.

Input Voltages	208 - 460 Volt Three Phase				
	208 VAC	230 VAC	460 VAC	575 VAC	
Power (KVA/Kw)	3 ph	16/12			
Current (Amps)	3 ph	44	40	20	N/A

Rated Output	Amps Volts Duty Cycle	300A 32V 60%	Contractor Control Current Control Analog Control Dimensions	Remote Input Remote or Panel 0 - 10 Volts DC Input Height: 25.59" (650 mm) Width: 15.75" (400 mm) Length: 23.62" (600 mm) Weight: 131 lbs. (59.4 kg)
Output Range Load Volts OCV Input Hz Flow Meters	5 - 300A 12 - 32V 60VDC 50/60Hz Plasma Shield	.5 - 3.0 SCFH (.25-1.5 lpm) 5 - 30 SCFH (2.5-15 lpm)		