

# THYRISTOR MODULE (NON-ISOLATED TYPE)

## PWB130A

PWB130A is a Thyristor module suitable for low voltage, 3 phase recifier applications.

- $I_{T(AV)}$ 130A (each device)
- high Surge Current 3500 A (50/60Hz)
- Easy Construction
- Non-isolated. Mounting base as common Anode terminal

### (Applications)

Welding power Supply  
Various DC power Supply

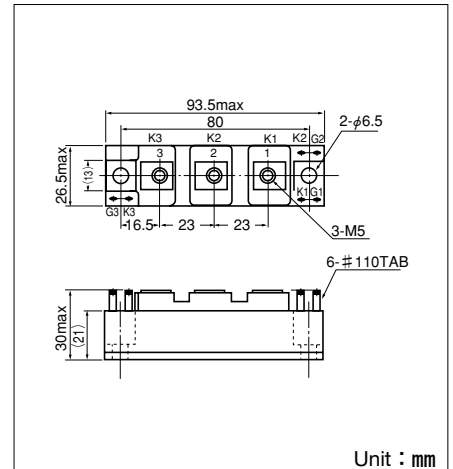
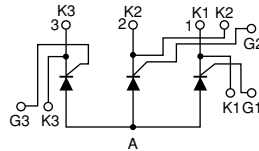

### Maximum Ratings

Symbol	Item	Ratings			Unit
		PWB130A20	PWB130A30	PWB130A40	
VRRM	Repetitive Peak Reverse Voltage	200	300	400	V
VRSM	Non-Repetitive Peak Reverse Voltage	240	360	480	V
VDRM	Repetitive Peak Off-State Voltage	200	300	400	V

Symbol	Item	Conditions	Ratings	Unit	
$I_{T(AV)}$	Average On-State Current	Single phase, half wave, 180° conduction, Tc : 112°C	130	A	
$I_{T(RMS)}$	R.M.S. On-State Current	Single phase, half wave, 180° conduction, Tc : 112°C	204	A	
$I_{TSM}$	Surge On-State Current	1/2cycle, 50Hz/60Hz, peak value, non-repetitive	3200/3500	A	
$I^2t$	$I^2t$		51000	A <sup>2</sup> S	
P <sub>GM</sub>	Peak Gate Power Dissipation		10	W	
P <sub>G(AV)</sub>	Average Gate Power Dissipation		1	W	
I <sub>FGM</sub>	Peak Gate Current		3	A	
V <sub>FGM</sub>	Peak Gate Voltage (Forward)		10	V	
V <sub>RGM</sub>	Peak Gate Voltage (Reverse)		5	V	
di/dt	Critical Rate of On-State Current	I <sub>G</sub> =200mA, T <sub>j</sub> =25°C, V <sub>D</sub> =1/2V <sub>DRM</sub> , dl <sub>G</sub> /dt=1A/μs	50	A/μs	
T <sub>j</sub>	Operating Junction Temperature		-30 to +150	°C	
T <sub>stg</sub>	Storage Temperature		-30 to +125	°C	
	Mounting torque	Mounting (M6)	Recommended 2.5-3.9 (25-40)	4.7 (48)	N·m (kgf·cm)
		Terminal (M5)	Recommended 1.5-2.5 (15-25)	2.7 (28)	
	Mass			170	g

### Electrical Characteristics

Symbol	Item	Conditions	Ratings			Unit
			Mix.	Typ.	Min.	
I <sub>DRM</sub>	Repetitive Peak Off-State Current, max.	at V <sub>DRM</sub> , single phase, half wave, T <sub>j</sub> =150°C			30	mA
I <sub>RRM</sub>	Repetitive Peak Reverse Current, max.	at V <sub>DRM</sub> , single phase, half wave, T <sub>j</sub> =150°C			30	mA
V <sub>TM</sub>	Peak On-State Voltage, max.	On-State Current 410A, T <sub>j</sub> =150°C Inst. measurement			1.2	V
I <sub>GT</sub>	Gate Trigger Current, max.	T <sub>j</sub> =25°C, I <sub>T</sub> =1A, V <sub>D</sub> =6V			150	mA/V
V <sub>GT</sub>	Gate Trigger Voltage, max.	T <sub>j</sub> =25°C, I <sub>T</sub> =1A, V <sub>D</sub> =6V			2	mA/V
V <sub>GD</sub>	Non-Trigger Gate, Voltage. min.	T <sub>j</sub> =150°C, V <sub>D</sub> =1/2V <sub>DRM</sub>	0.25			V
t <sub>gt</sub>	Turn On Time, max.	I <sub>T</sub> =100A, I <sub>G</sub> =200mA, T <sub>j</sub> =25°C, V <sub>D</sub> =1/2V <sub>DRM</sub> , dl <sub>G</sub> /dt=1A/μs			10	μs
dv/dt	Critical Rate of Rise of Off-State Voltage, min.	T <sub>j</sub> =150°C, V <sub>D</sub> =2/3V <sub>DRM</sub> , Exponential wave.	50			V/μs
I <sub>H</sub>	Holding Current, typ.	T <sub>j</sub> =25°C			70	mA
R <sub>th(j-c)</sub>	Thermal Impedance, max.	Junction to case (1/3 Module)			0.2	°C/W

**Gate Characteristics**

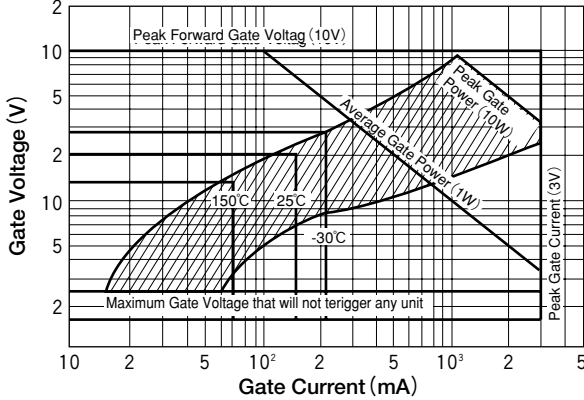

**On-State Voltage max**

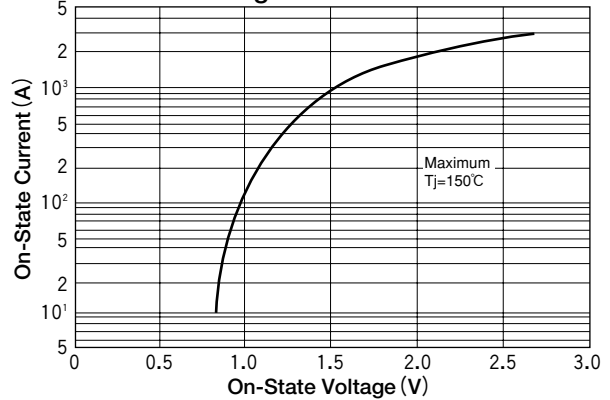

**Average On-State Current Vs Power Dissipation (Single phase half wave)**

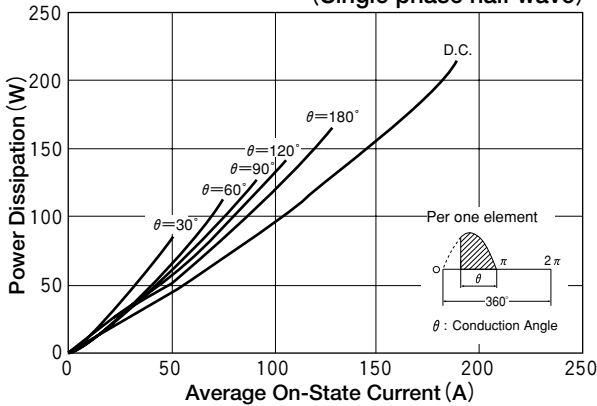

**Average On-State Current Vs Maximum Allowable Case Temperature (Single phase half wave)**

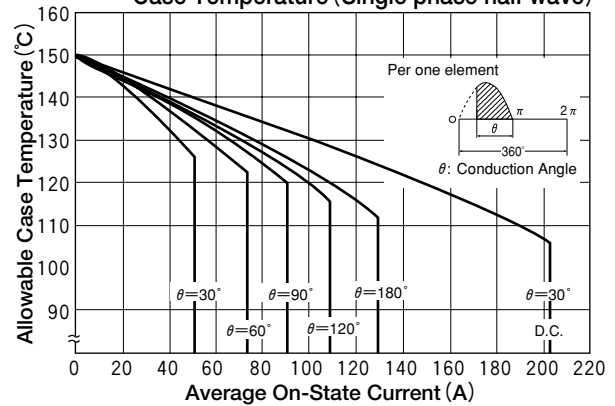

**Surge On-State Current Rating (Non-Repetitive)**

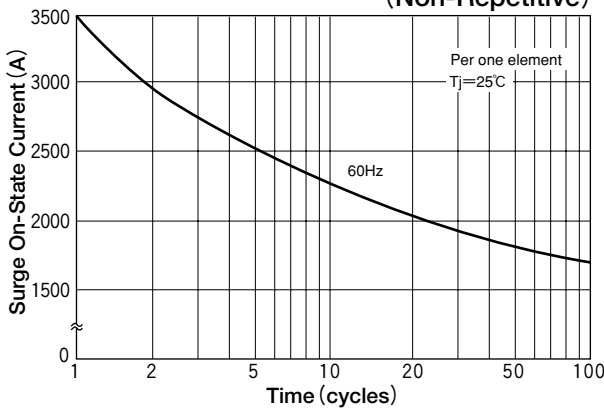

**Transient Thermal Impedance**

