

# THYRISTOR MODULE

# PK(PD,PE)90FG

UL;E76102 (M)

Power Thyristor/Diode Module PK90FG series are designed for various rectifier circuits and power controls. For your circuit application, following internal connections and wide voltage ratings up to 1600V are available. and electrically isolated mounting base make your mechanical design easy.

- $I_{T(AV)}$  90A,  $I_{T(RMS)}$  140A,  $I_{TSM}$  2300A
- $di/dt$  100A/ $\mu$ s
- $dv/dt$  1000V/ $\mu$ s

### (Applications)

Various rectifiers  
AC/DC motor drives  
Heater controls  
Light dimmers  
Static switches

### Internal Configurations

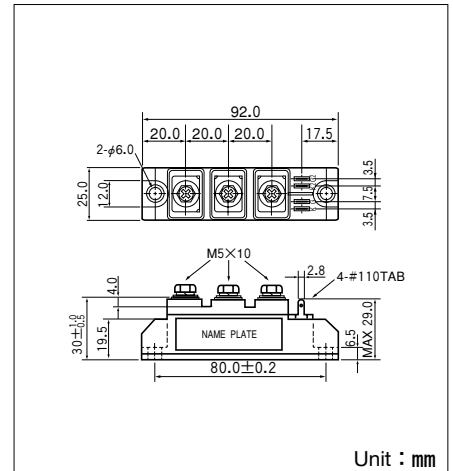
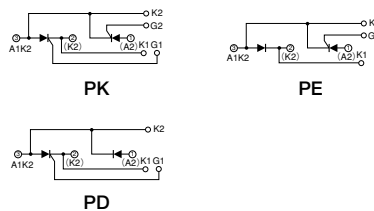

Unit : mm

### Maximum Ratings

( $T_j=25^\circ\text{C}$  unless otherwise specified)

Symbol	Item	Ratings				Unit
		PK90FG40 PD90FG40 PE90FG40	PK90FG80 PD90FG80 PE90FG80	PK90FG120 PD90FG120 PE90FG120	PK90FG160 PD90FG160 PE90FG160	
$V_{RRM}$	* Repetitive Peak Reverse Voltage	400	800	1200	1600	V
$V_{RSM}$	* Non-Repetitive Peak Reverse Voltage	480	960	1300	1700	V
$V_{DRM}$	* Repetitive Peak off-state Voltage	400	800	1200	1600	V

Symbol	Item	Conditions	Ratings	Unit	
$I_{T(AV)}$	* Average On-state Current	Single phase, half wave, $180^\circ$ conduction, $T_c=82^\circ\text{C}$	90	A	
$I_{T(RMS)}$	* R.M.S. On-state Current	Single phase, half wave, $180^\circ$ conduction, $T_c=82^\circ\text{C}$	140	A	
$I_{TSM}$	* Surge On-state Current	$\frac{1}{2}$ Cycle, 50/60Hz, Peak Value, non-repetitive	2100/2300	A	
$I^2t$	* $I^2t$	Value for one cycle surge current	22040	$\text{A}^2\text{S}$	
$P_{GM}$	Peak Gate Power Dissipation		10	W	
$P_{G(AV)}$	Average Gate Power Dissipation		1	W	
$I_{FGM}$	Peak Gate Current		3	A	
$V_{FGM}$	Peak Gate Voltage (Forward)		10	V	
$V_{RGM}$	Peak Gate Voltage (Reverse)		5	V	
$di/dt$	Critical Rate of Rise of On-state Current	$I_G=100\text{mA}$ , $V_D=\frac{1}{2}V_{DRM}$ , $di_G/dt=0.1\text{A}/\mu\text{s}$	100	$\text{A}/\mu\text{s}$	
$V_{ISO}$	* Isolation Breakdown Voltage (R.M.S.)	A.C. 1minute	2500	V	
$T_j$	* Operating Junction Temperature		-40 to +125	$^\circ\text{C}$	
$T_{stg}$	* Storage Temperature		-40 to +125	$^\circ\text{C}$	
	Mounting Torque	Mounting (M5)	Recommended Value 1.5-2.5 (15-25)	2.7 (28)	N·m (kgf·cm)
		Terminal (M5)	Recommended Value 1.5-2.5 (15-25)	2.7 (28)	
	Mass	Typical Value	170	g	

### Electrical Characteristics

( $T_j=25^\circ\text{C}$  unless otherwise specified)

Symbol	Item	Conditions	Ratings	Unit
$I_{DRM}$	Repetitive Peak off-state Current,max	$T_j=125^\circ\text{C}$ , $V_D=V_{DRM}$	25	mA
$I_{RRM}$	* Repetitive Peak Reverse Current,max	$T_j=125^\circ\text{C}$ , $V_D=V_{DRM}$	25	mA
$V_{TM}$	* On-state Voltage,max	$I_T=270\text{A}$	1.6	V
$I_{GT}$	Gate Trigger Current,max	$V_D=6\text{V}$ , $I_T=1\text{A}$	50	mA
$V_{GT}$	Gate Trigger Voltage,max	$V_D=6\text{V}$ , $I_T=1\text{A}$	3	V
$V_{GD}$	Gate Non-Trigger Voltage,min	$T_j=125^\circ\text{C}$ , $V_D=\frac{1}{2}V_{DRM}$	0.25	V
$dv/dt$	Critical Rate of Rise of off-state Voltage,min	$T_j=125^\circ\text{C}$ , $V_D=\frac{2}{3}V_{DRM}$	1000	$\text{V}/\mu\text{s}$
$R_{th(j-c)}$	* Thermal Impedance,max	Junction to case	0.3	$^\circ\text{C}/\text{W}$

\* mark : Thyristor and Diode part. No mark : Thyristor part

