

THYRISTOR MODULE (SINGLE PHASE BRIDGE TYPE)

FSD20A30/60

UL:E76102 (M)

FSD20A is a single phase bridge module consist of thyristors and diodes

- $I_D=20A$, $V_{RRM}=600V$
- Easy Construction
- Highly reliable glass passivated chips

(Applications)

Rectification (Bridge)
Motor Drive

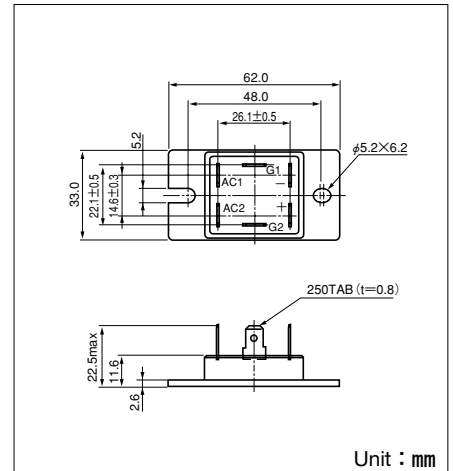
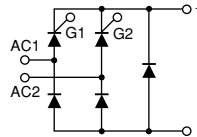

Unit : mm

Maximum Ratings

($T_j=25^\circ\text{C}$ unless otherwise specified)

Symbol	Item	Ratings		Unit
		FSD20A30	FSD20A60	
V_{RRM}	Repetitive Peak Reverse Voltage	300	600	V
V_{DRM}	Repetitive Peak Off-State Voltage	300	600	V

Symbol	Item	Conditions	Ratings	Unit
$I_{T(AV)}$	Average On-State Current	Single phase, half wave, 180° conduction, $T_c : 65^\circ\text{C}$	20	A
I_{TSM}	Surge On-State Current	$\frac{1}{2}$ cycle, 50Hz/60Hz, peak value, non-repetitive	180/200	A
I^2t	I^2t		165	A^2S
P_{GM}	Peak Gate Power Dissipation		10	W
$P_{G(AV)}$	Average Gate Power Dissipation		1	W
I_{FGM}	Peak Gate Current		3	A
V_{FGM}	Peak Gate Voltage (Forward)		10	V
V_{RGM}	Peak Gate Voltage (Reverse)		5	V
di/dt	Critical Rate of On-State Current	$I_G=100\text{mA}$, $T_j=25^\circ\text{C}$, $V_D=\frac{1}{2}V_{DRM}$, $di_G/dt=1\text{A}/\mu\text{s}$	100	$\text{A}/\mu\text{s}$
V_{ISO}	Isolation Breakdown Voltage (R.M.S.)	A.C.1minute	2500	V
T_j	Operating Junction Temperature		-30 to +125	$^\circ\text{C}$
T_{stg}	Storage Temperature		-30 to +125	$^\circ\text{C}$
	Mounting Torque (M5)	Recommended Value 1.5-2.5 (15-25)	2.7 (28)	$\text{N}\cdot\text{m}$ ($\text{kgf}\cdot\text{cm}$)
	Mass		66	g

Electrical Characteristics

Symbol	Item	Conditions	Ratings	Unit
I_{DRM}	Repetitive Peak Off-State Current, max.	at V_{DRM} , single phase, half wave, $T_j=125^\circ\text{C}$	5	mA
I_{RRM}	Repetitive Peak Reverse Current, max.	at V_{DRM} , single phase, half wave, $T_j=125^\circ\text{C}$	5	mA
V_{TM}	Peak On-State Voltage, max.	On-State Current 30A, $T_j=25^\circ\text{C}$ Inst. measurement	1.5	V
I_{GT}/V_{GT}	Gate Trigger Current/Voltage, max.	$T_j=25^\circ\text{C}$, $I_T=1\text{A}$, $V_D=6\text{V}$	40/1.2	mA/V
V_{GD}	Non-Trigger Gate, Voltage. min.	$T_j=125^\circ\text{C}$, $V_D=\frac{1}{2}V_{DRM}$	0.2	V
t_{gt}	Turn On Time, max.	$I_T=10\text{A}$, $I_G=100\text{mA}$, $T_j=25^\circ\text{C}$, $V_D=\frac{1}{2}V_{DRM}$, $di_G/dt=1\text{A}/\mu\text{s}$	10	μs
dv/dt	Critical Rate of Rise of Off-State Voltage, min.	$T_j=125^\circ\text{C}$, $V_D=\frac{2}{3}V_{DRM}$, Exponential wave.	50	$\text{V}/\mu\text{s}$
I_H	Holding Current, typ.	$T_j=25^\circ\text{C}$	30	mA
$R_{th(j-c)}$	Thermal Impedance, max.	Junction to case	1.0	$^\circ\text{C}/\text{W}$

